

elysium
NOVELLINI INTERNATIONAL DESIGN



cristal 1

Istruzioni

Instructions

Instructions

Instrucciones

1

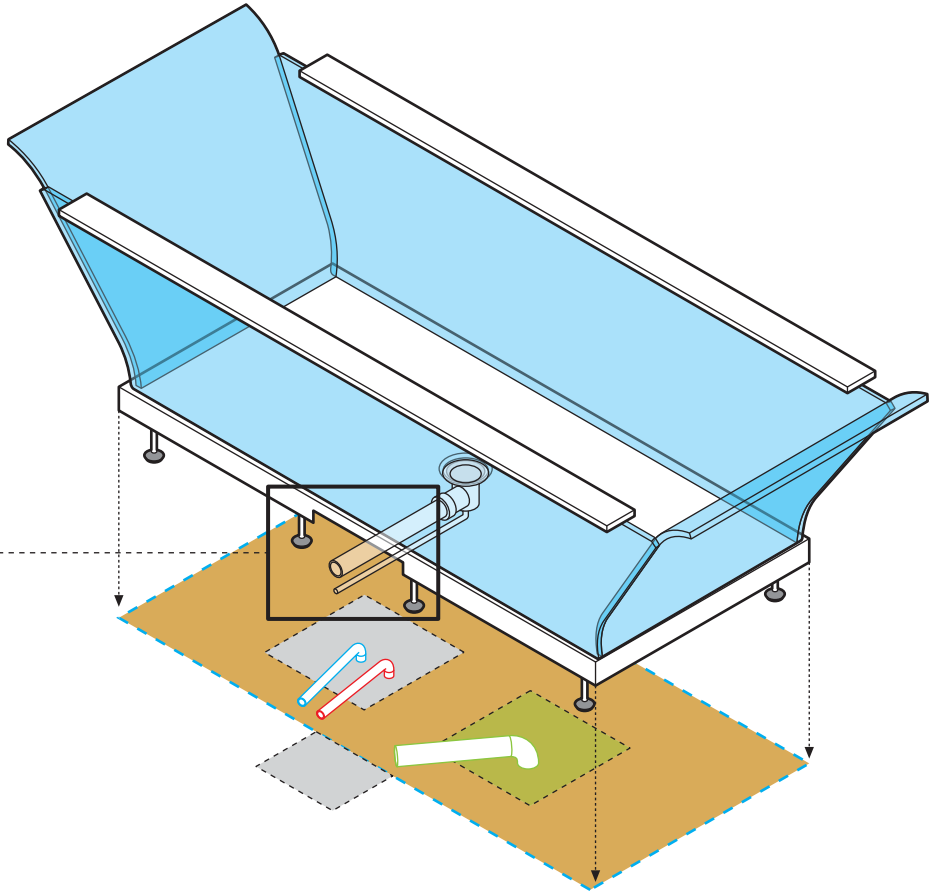
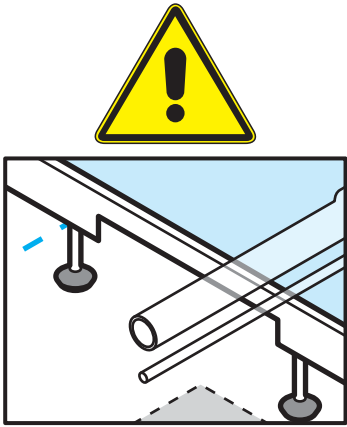

2

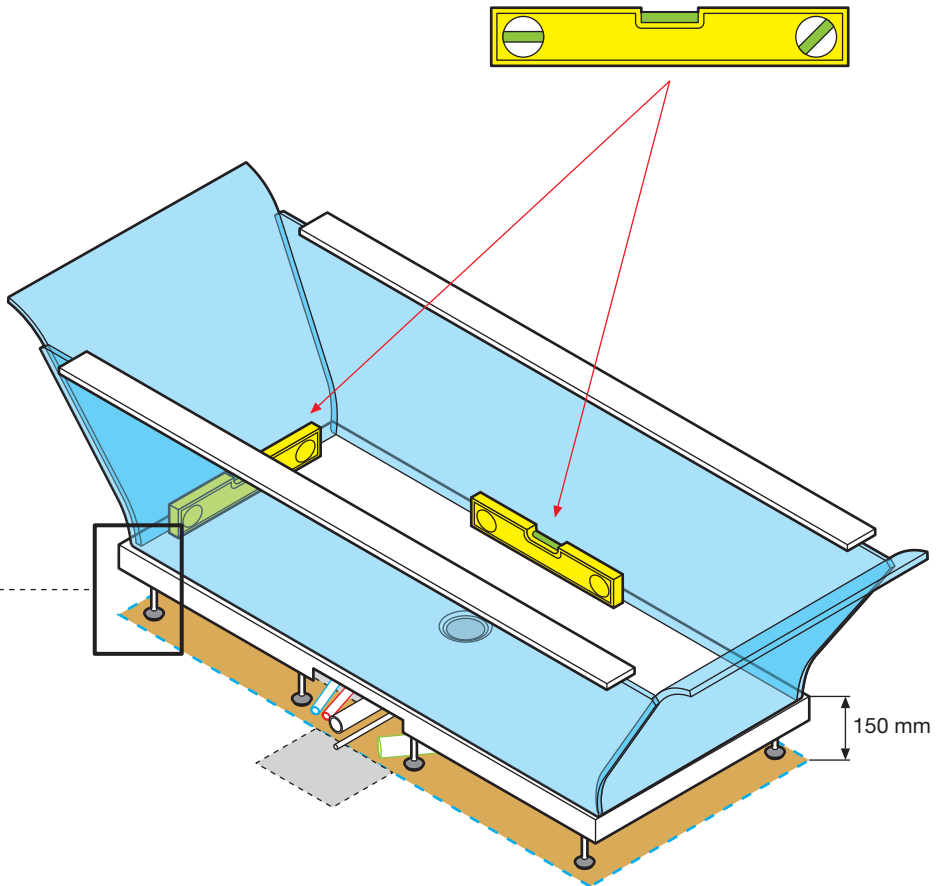
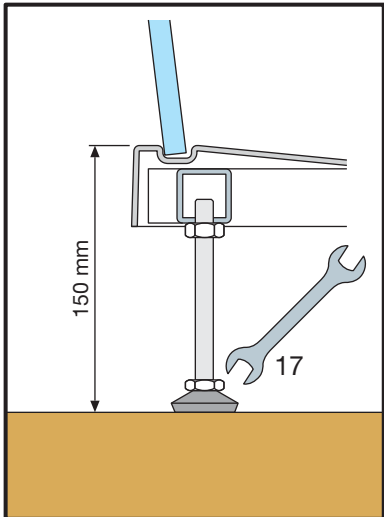

3

3

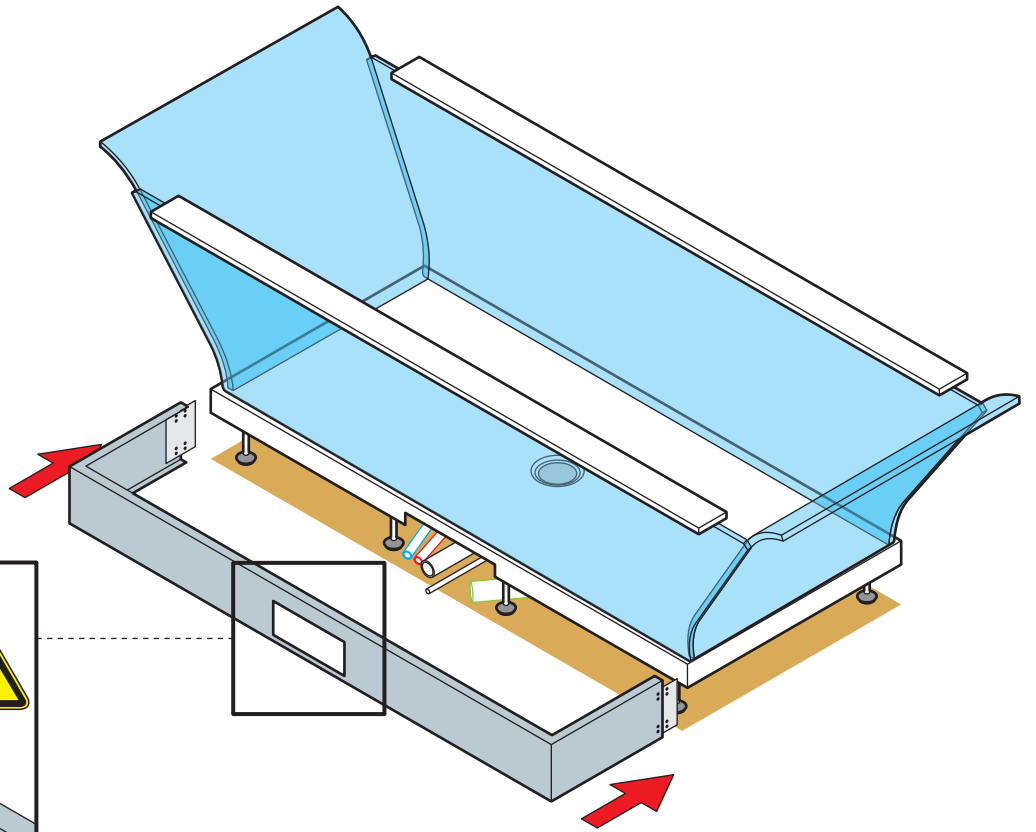
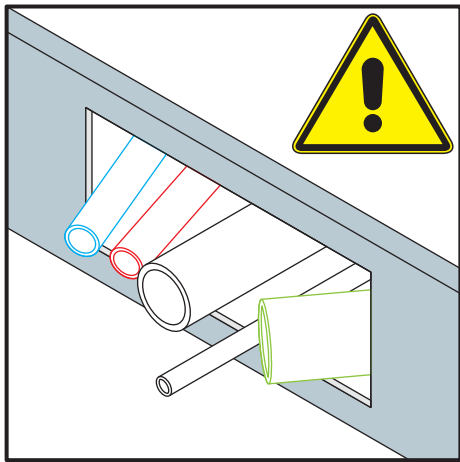

4

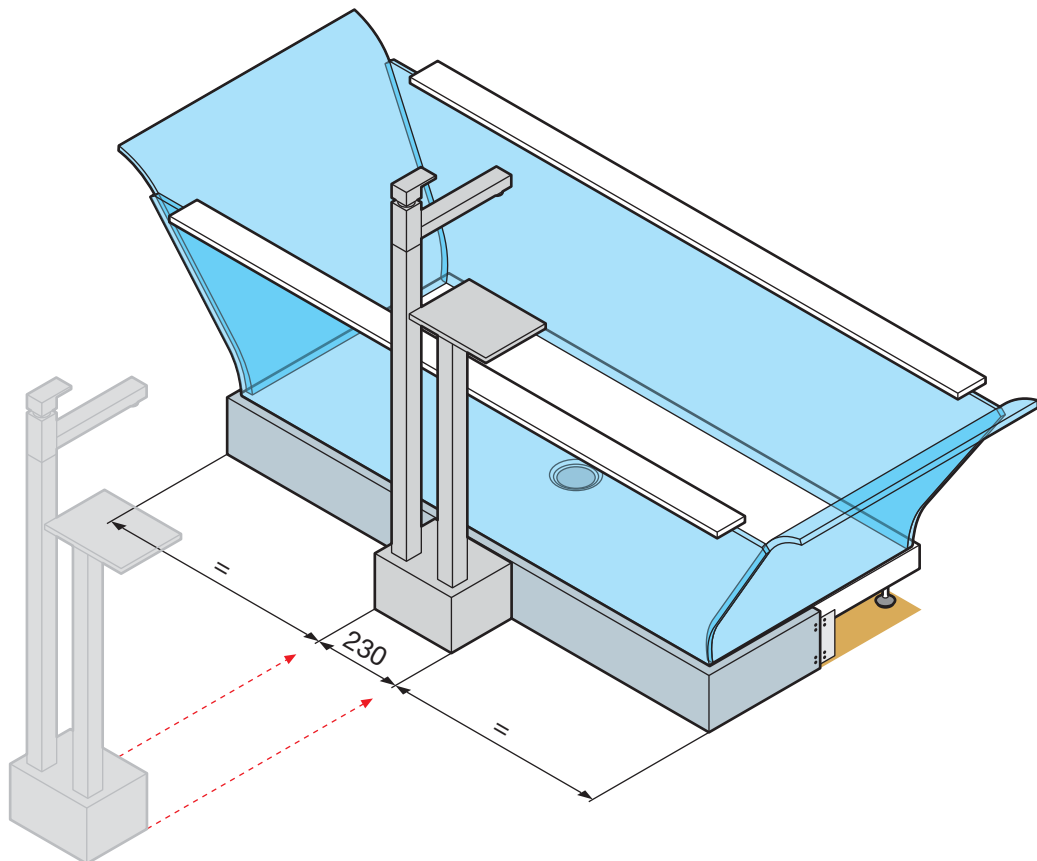

4

5

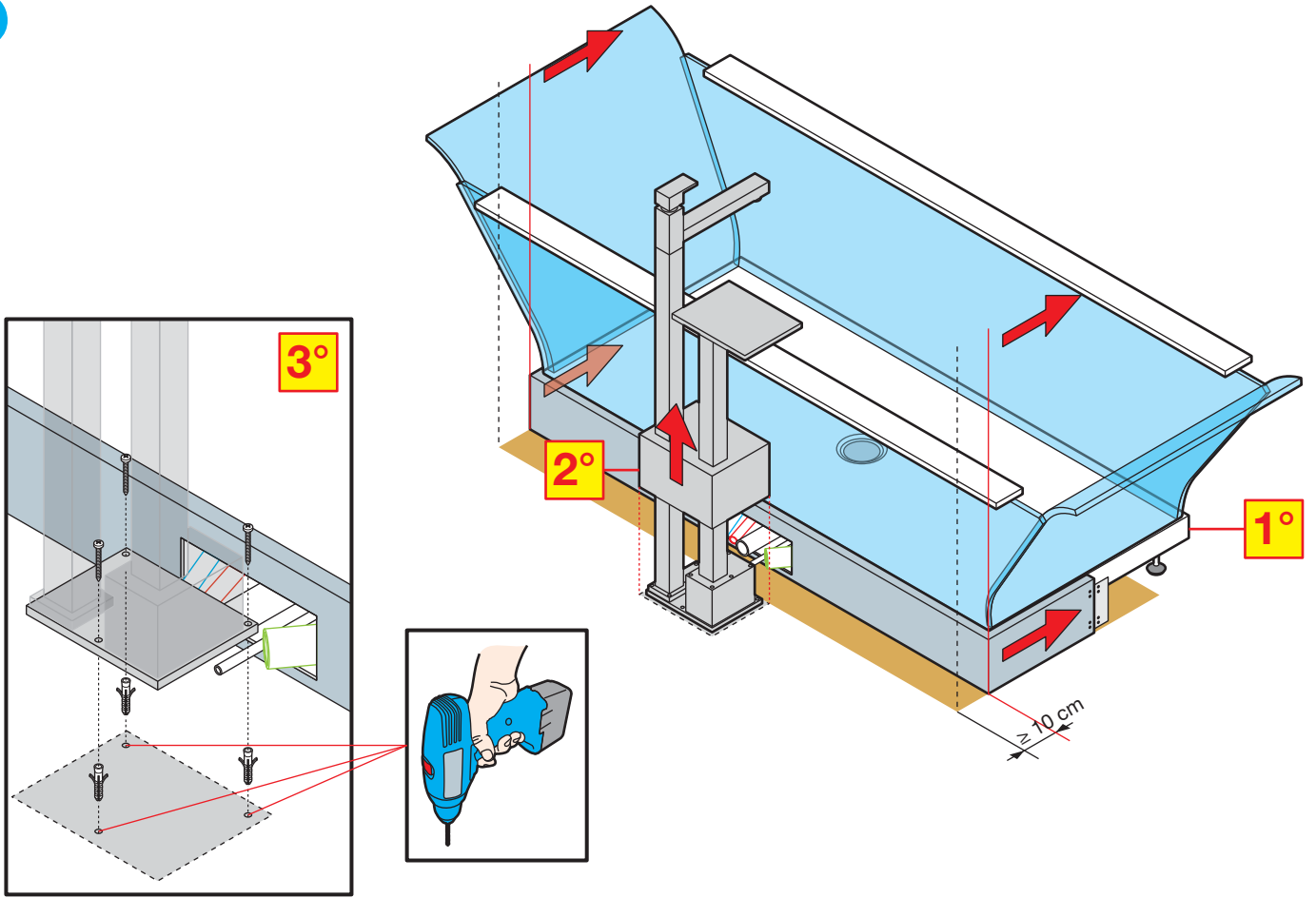

6

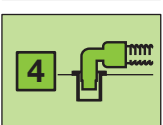
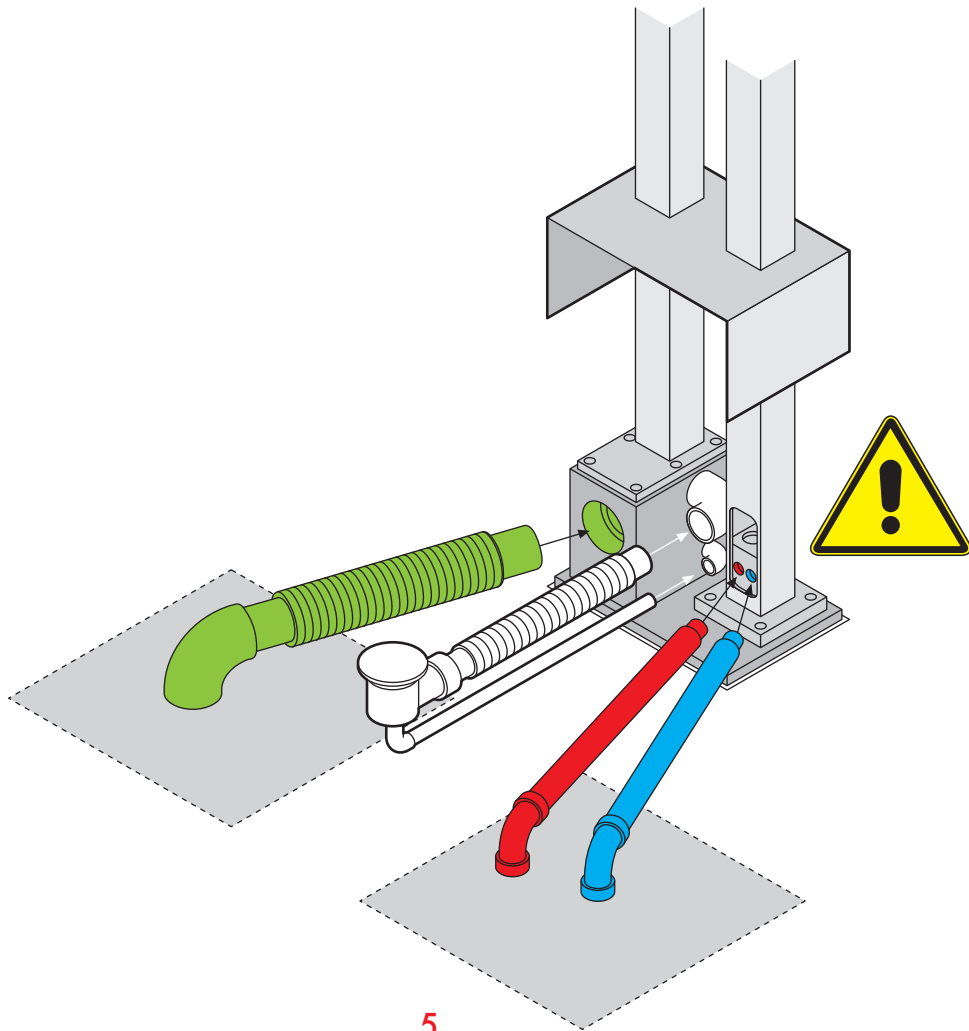

5

7

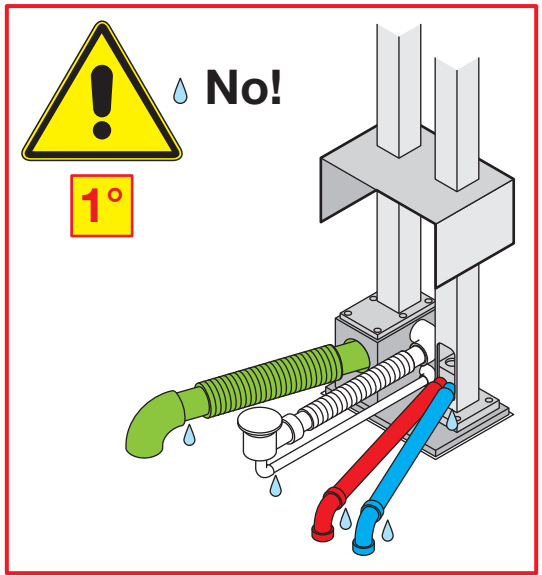
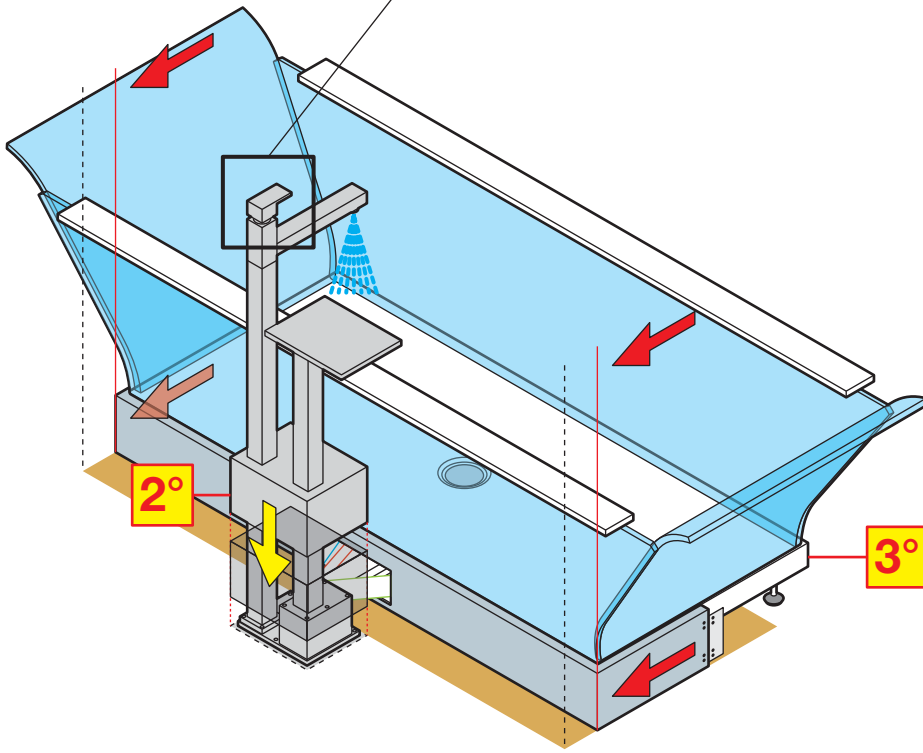
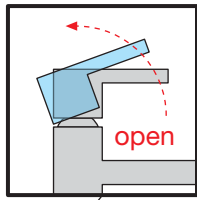

- IT Collaudo tenuta acqua
- FR Vérification de l'étanchéité
- UK Waterproof test
- DE Prüfung der Dichtheit
- NL Waterdichtheidstest
- ES Prueba de estanqueidad al agua
- CZ Kontrola vodotěsnosti
- SL Pregled vodotesnosti
- HU Vízzivárgási próba
- PL Sprawdzenie wod szczelności
- RU Испытание на герметичность
- PT Verificação da estanquidade à água

8

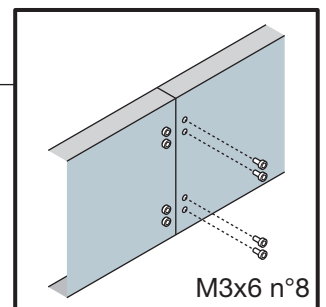
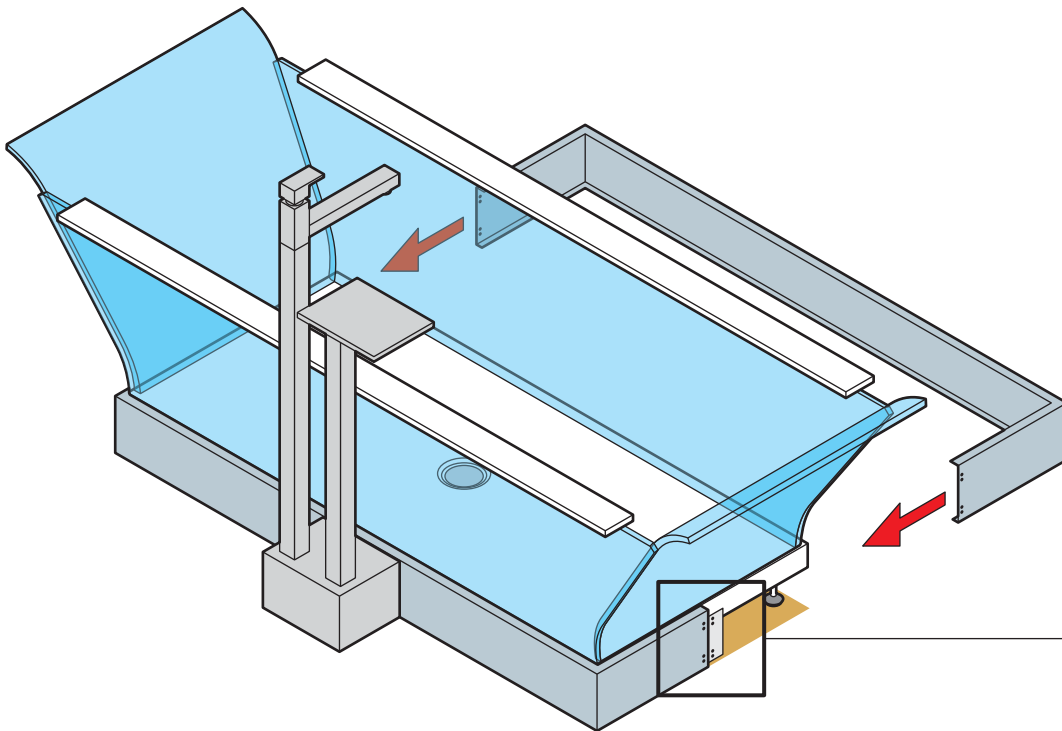

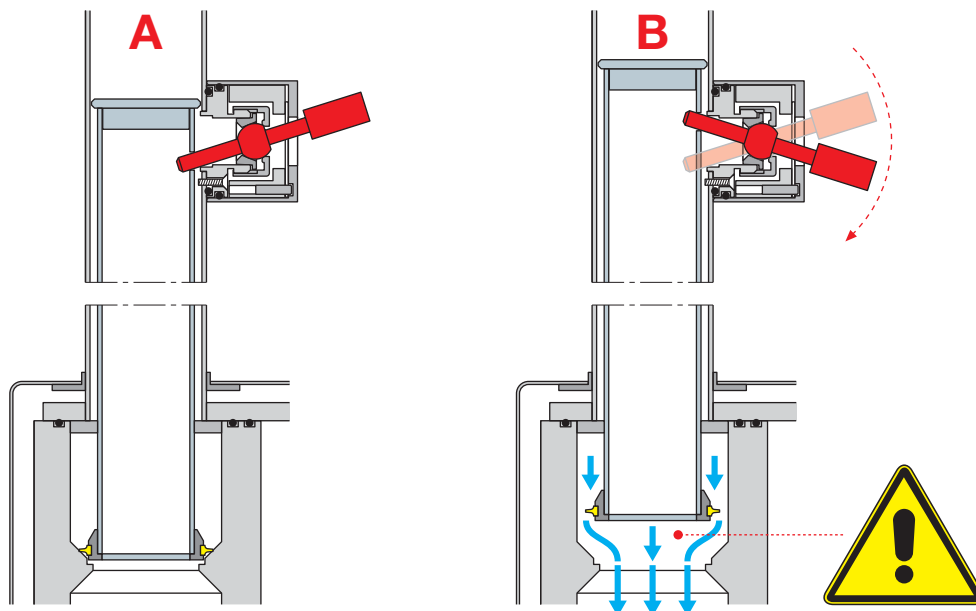

IT ATTENZIONE:
IL RIEMPIMENTO DELLA VASCA DEVE AVVENIRE CON ACQUA TIEPIDA:
LA TEMPERATURA PUO' GRADUALMENTE ESSERE INCREMENTATA
SENZA MAI SUPERARE I 65°C PER EVITARE INCRINATURE E ROTTURE.

FR ATTENTION!
LE BAC DOIT ÊTRE REMPLI AVEC DE L'EAU TIÈDE:
LA TEMPÉRATURE PEUT ÊTRE AUGMENTÉE GRADUELLEMENT SANS
JAMAIS DÉPASSER 65°C AFIN D'ÉVITER TOUTE FISSURE ET TOUTE
RUPTURE.

UK IMPORTANT:
THE BATH MUST BE FILLED WITH LUKEWARM WATER:
THE TEMPERATURE CAN BE GRADUALLY INCREASED, BUT MUST
NEVER EXCEED 65°C TO AVOID CRACKS AND BREAKAGE.

DE ACHTUNG:
DIE WANNE MUSS MIT LAUWARMEM WASSER GEFÜLLT WERDEN:
DIE TEMPERATUR KANN ALLMÄHLICH ERHÖHT WERDEN. DABEI
DÜRFEN 65 °C NICHT ÜBERSCHRITTEN WERDEN, UM RISSE UND
BESCHÄDIGUNGEN ZU VERMEIDEN.

NL LET OP:
HET BAD MOET WORDEN GEVULD MET LAUW WATER:
DE TEMPERATUUR KAN GELEIDELIJK WORDEN VERHOOGD, ZONDER
DE 65°C TE OVSCHRIJDEN, OM BARSTEN EN BREUK TE VERMIJDEN.

ES ATENCIÓN:
LA BAÑERA SE DEBE LLENAR CON AGUA TIBIA:
LA TEMPERATURA SE PUEDE AUMENTAR GRADUALMENTE, SIN
SUPERAR NUNCA 65 °C PARA EVITAR LA FORMACIÓN DE GRIETAS
Y RUPTURAS.

CZ UPOZORNĚNÍ:
VANA MUSÍ BÝT NAPLNĚNA VLAŽNOU VODOU:
TEPLOTA MŮŽE BÝT POSTUPNĚ ZVYŠOVÁNA, ALE NESMÍ NIKDY
PŘESÁHNOUT 65°C, ABY NEDOŠLO K PRASKLINÁM A POŠKOZENÍ.

SL POZOR:
KAD MORA BITI POLNJENA Z MLAČNO VODO:
TEMPERATURO JE MOŽNO POSTOPOMA POVIŠEVATI, VENDAR NI
DOVOLJENO PREKORACITI 65°C, DA SE PREPREČI RAZPOKANJE IN
POŠKODBE.

HU FIGYELEM!
A KÁDAT LANGYOS VÍZZEL KELL FELTÖLTENI:
A HÖMÉRSEKLETET FOKOZATOSAN LEHET EMELNI, DE A REPEDÉSEK
ÉS TÖRÉSEK ELKERÜLÉSE ÉRDEKÉBEN SOSEM SZABAD TÜLLÉPNI
A 65°C-OT.

PL UWAGA!
WANNA WINNA BYĆ NAPEŁNIONA LETNIĄ WODĄ:
TEMPERATURĘ MOŻNA STOPNIOWO ZWIĘKSZYĆ, NIE
PRZEKRACZAJĄC JEDNAK 65°C, BY UNIKNĄĆ PĘKNIĘĆ I ZŁAMAN.

RU ВНИМАНИЕ!
ВАННУ СЛЕДУЕТ НАПОЛНИТЬ ТЕПЛОЙ ВОДОЙ:
ТЕМПЕРАТУРУ МОЖНО ПОВЫСИТЬ ПОСТЕПЕННО, НО НИКОГДА
НЕ ПРЕВЫШАЯ 65°C, ЧТОБЫ НЕ ВЫЗВАТЬ ТРЕЩИН И ПОЛОМКИ.

PT ATENÇÃO!
O ENCHIMENTO DA BANHEIRA DEVE SER FEITO COM ÁGUA MORNA:
A TEMPERATURA PODE SER AUMENTADA GRADUALMENTE, MAS
SEM NUNCA ULTRAPASSAR 65°C, PARA EVITAR FISSURAÇÃO E
DANOS.

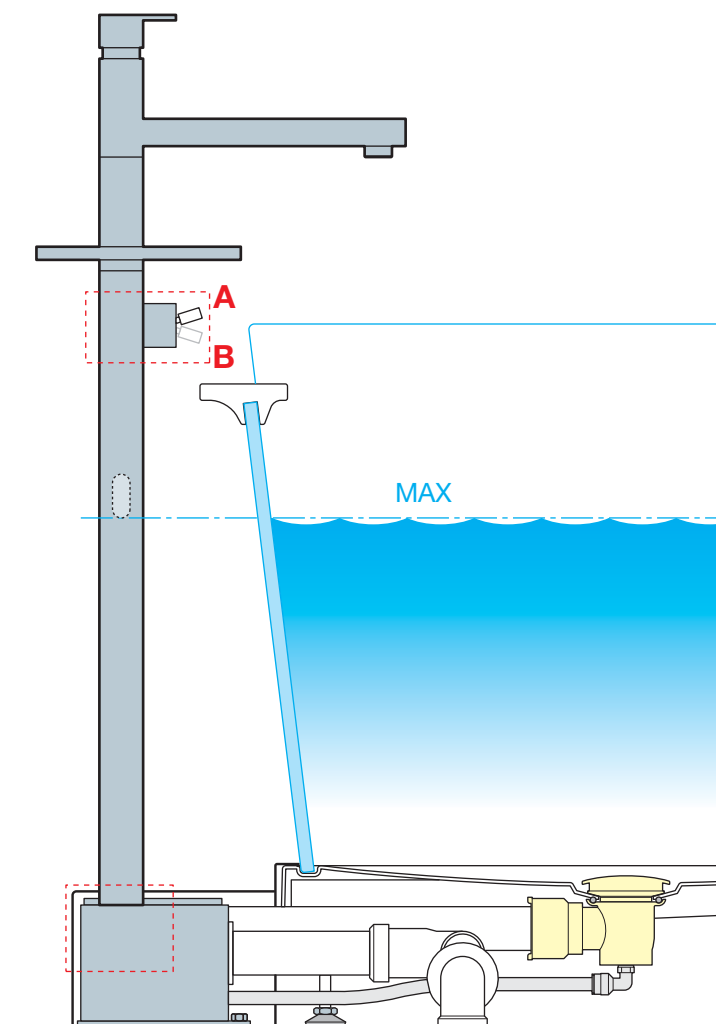



Novellini

NOVELLINI S.p.A.

Via della Stazione, 2 - 46030 Romanore di - Borgoforte (Mn)

Tel. +39 0376 6421 - Fax +39 0376 642250 - e-mail: novellini@novellini.it

www.novellini.com