

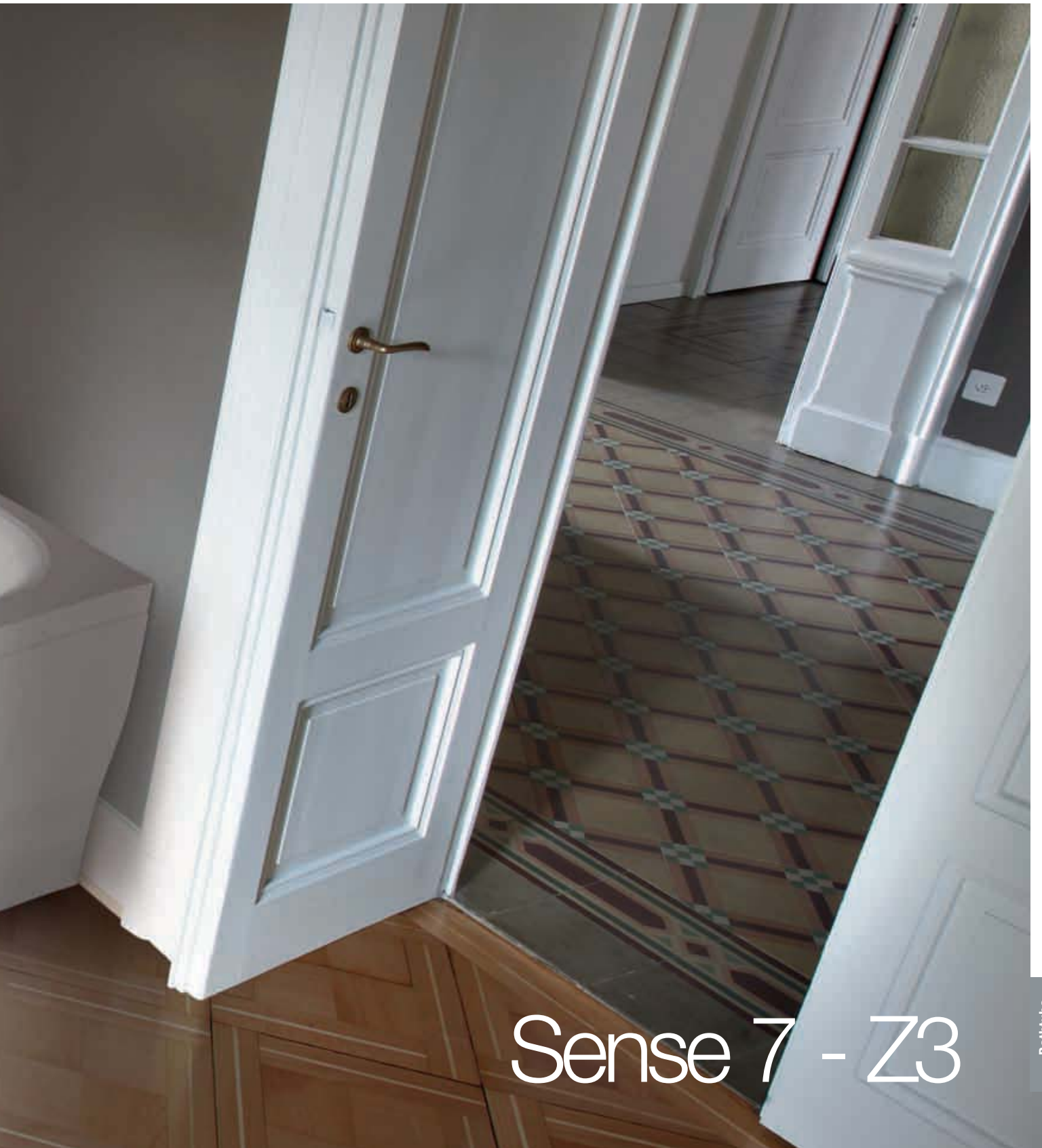



# Bathtubs





# Sense 7 - Z3

Bathtub

# Sense 7 - Z3

Corner standing bathtub

cm 140x140 capacity 235 lt.

## FEATURES



Bath mounted cascade mixer



Whirlpool 6 jets with flow regulation and closing system



Chromo light



Airpool 10 jets



Back airpool 6 nozzles



Electronic panel with hydro sequence function



Head rest



Disinfection system

Waste column

## OPTIONAL



KRUBBAS-K

FLOOR MOUNTED BATHTUB FILLER



COLSCAVK-K

WASTE COLUMN



PANISPEL-A

INSPECTION PANEL FOR BUILT-IN BATHTUBS 60x33 CM



PRV140140-30

BATHTUB EDGE PROFILE

Measurements (cm)	Bathtub	Code	Price	Bathtub	Code	Price
		WITHOUT bath mounted cascade mixer			WITH bath mounted cascade mixer	

### STANDARD VERSION

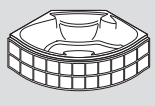
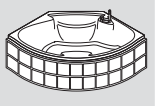
140 x 140 x 58 H		<b>Z31140140-A</b>			<b>Z311401402-A0K</b>	
------------------	---	--------------------	--	--	-----------------------	--

FEATURES: Head rest (WASTE COLUMN NOT INCLUDED)

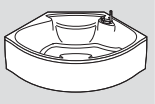
140 x 140 x 58 H		<b>Z32140140-A1</b>			<b>Z321401402-A1K</b>	
------------------	---	---------------------	--	--	-----------------------	--

FEATURES: Frame, front panel, head rest, waste column

### HYDRO VERSION

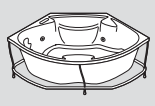
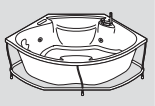
HYDRO VERSION	140 x 140 x 58 H		<b>Z35140140R0-A0K</b>			<b>Z35140140R2-A0K</b>	
---------------	------------------	--	------------------------	--	---	------------------------	--

FEATURES: Frame, head rest, waste column, whirlpool 6 jets, electronic panel

140 x 140 x 58 H		<b>Z35140140R0-A1K</b>			<b>Z35140140R2-A1K</b>	
------------------	---	------------------------	--	--	------------------------	--

FEATURES: Frame, front panel, head rest, waste column, whirlpool 6 jets, electronic panel

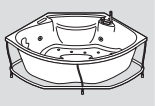
PLUS VERSION	140 x 140 x 58 H		<b>Z37140140R6-A0K</b>			<b>Z37140140R7-A0K</b>	
--------------	------------------	---	------------------------	--	--	------------------------	--

FEATURES: Frame, head rest, waste column, whirlpool 6 jets, airpool 10 jets, back airpool 6 nozzles, electronic panel, Chromo light, Disinfection system

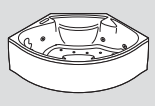
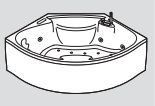
140 x 140 x 58 H		<b>Z37140140R6-A1K</b>			<b>Z37140140R7-A1K</b>	
------------------	---	------------------------	--	--	------------------------	--

FEATURES: Frame, front panel, head rest, waste column, whirlpool 6 jets, airpool 10 jets, back airpool 6 nozzles, electronic panel, Chromo light, Disinfection system



**Compulsory**  
Imperial to Metric flex  
waste adaptor

Code	<b>RISCCAB</b>
Price	

For technical diagrams see page 213.

## FLOOR-MOUNTED MIXER

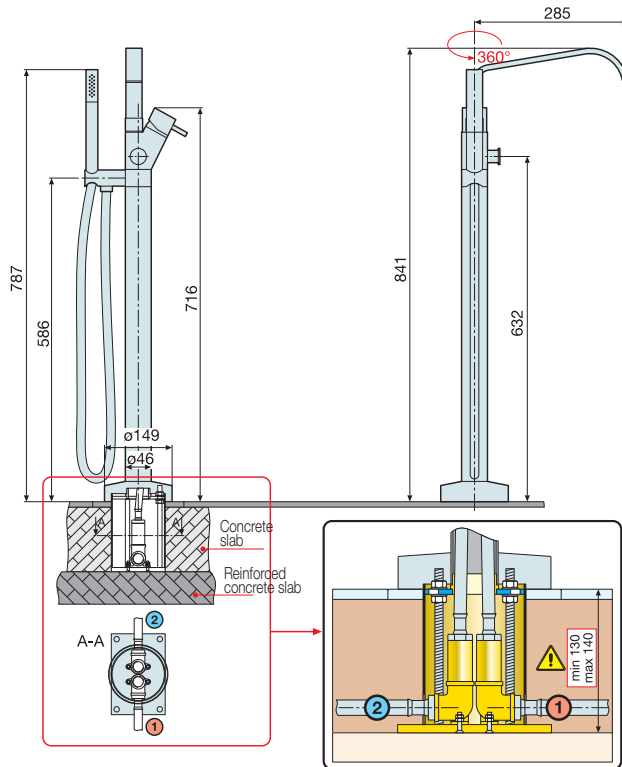

**ATTENTION:**

The column base must be installed before floor foundation. Please comply with the given measurements.

**HYDRAULIC CHARACTERISTICS**

- Optimum dynamic pressure 2-5 bar
- Bath filler water flow rate: 16 lit/min at 3 bar.
- Hand Shower water flow rate: 11 lit/min at 3 bar.

## SENSE 1

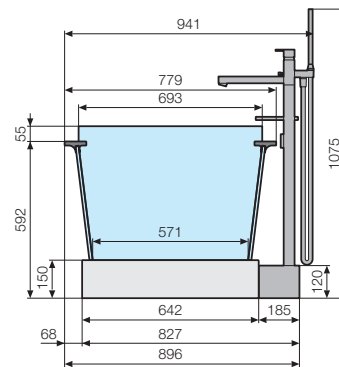
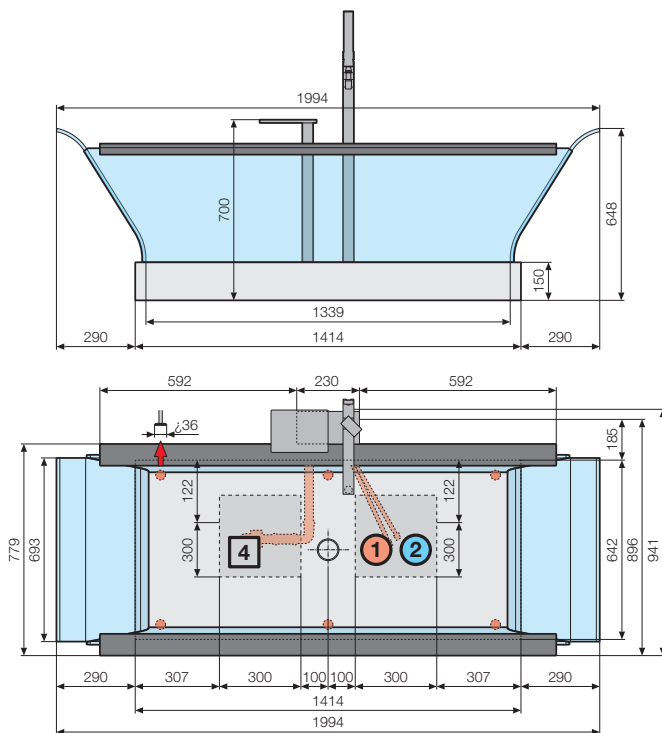

4 Recommended position for floor drainpipe.

**HYDRAULIC CHARACTERISTICS**

- Syphon connection 1 1/2"

SENSE 7 - Z1

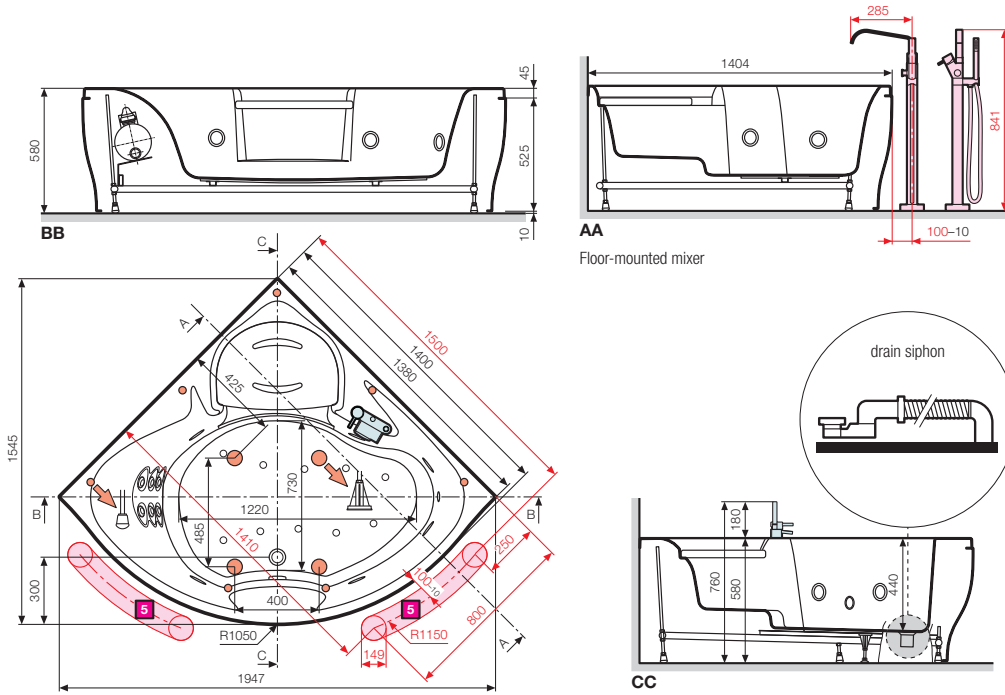

SENSE 7 - Z2

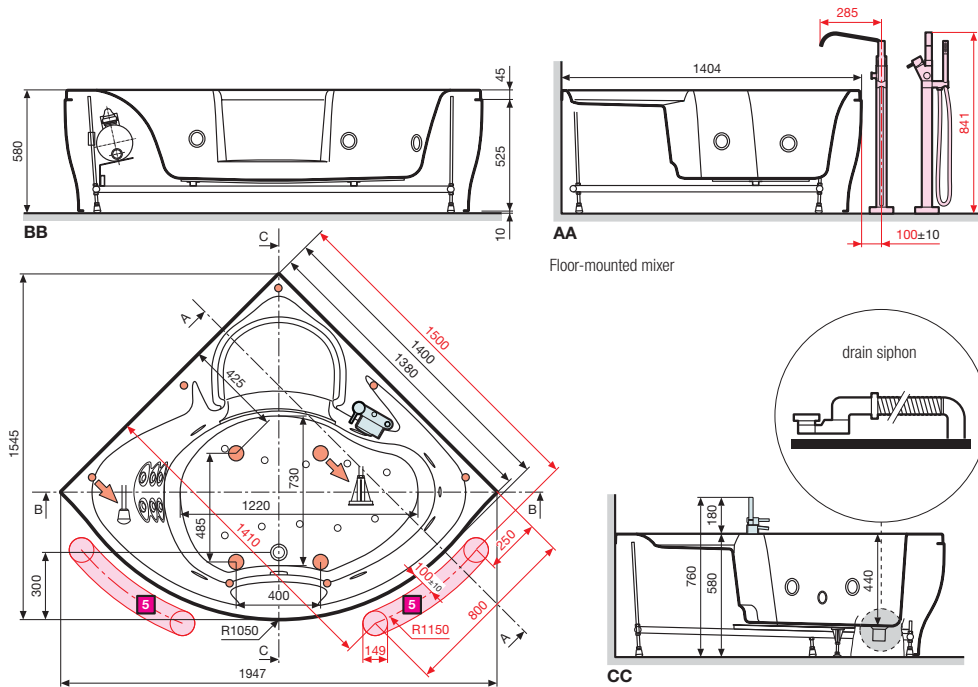

 <b>1</b> 1/2"	 <b>2</b> 1/2"	 <b>3</b>
 Wall installation (not supplied)		
 <b>4</b> Recommended position for floor drainpipe.	 <b>5</b> Available area for floor mounted mixer installation	

The whirlpool bath system must be fitted upstream with a 30 mA circuit breaker with a minimum contact of 3mm.

**HYDRAULIC CHARACTERISTICS**

- 6 whirlpool nozzles
- 10 airpool nozzles
- 6 back airpool nozzles
- Siphon connection with 1 1/2" coupling

**ELECTRICAL CHARACTERISTICS**

- Voltage 220-230 V
- Frequency 50 Hz
- Maximum absorbed power: whirlpool 880 W, airpool 900 W, whirlpool + airpool: 1800 W

## SENSE 7 - Z3

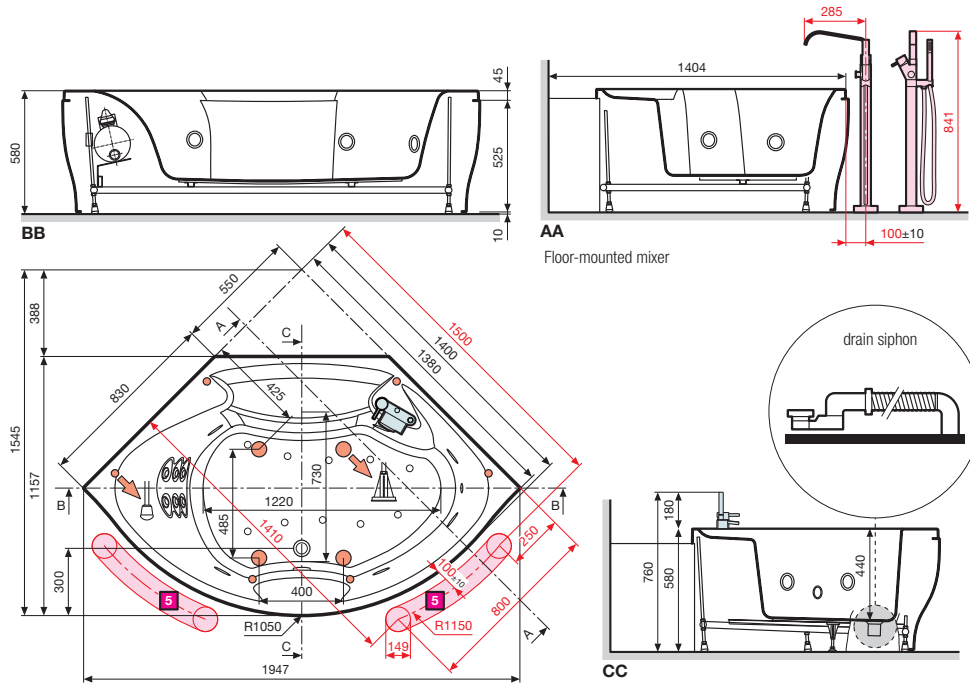

## SENSE 7 - Z1 - Z2 - Z3

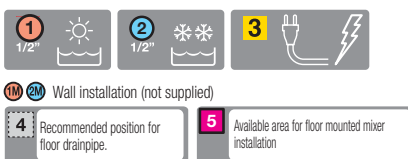
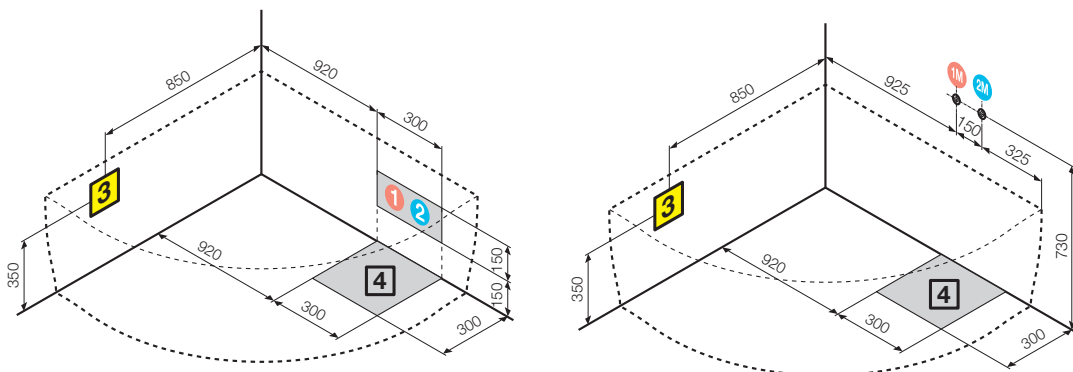

Floor mounted mixer technical drawings pag. 202

The whirlpool bath system must be fitted upstream with a 30 mA circuit breaker with a minimum contact of 3mm.

### HYDRAULIC CHARACTERISTICS

- 6 whirlpool nozzles
- 10 airpool nozzles
- 6 back airpool nozzles
- Siphon connection with 1 1/2" coupling

### ELECTRICAL CHARACTERISTICS

- Voltage 220-230 V
- Frequency 50 Hz
- Maximum absorbed power: whirlpool 880 W, airpool 900 W, whirlpool + airpool: 1800 W