





Bathtubs





Sense 5 - X3

Bathtub

Sense 5 - X3

Wall standing bathtub

cm 190x93 capacity 225 lt.

FEATURES



2 Head rests



Bath mounted cascade mixer



Chromo light



Disinfection system



Removable seat



Back airpool 6 nozzles



Electronic panel with hydro sequence function

Waste column



Airpool 12 jets



Whirlpool 6 jets with flow regulation and closing system

OPTIONAL



FLOOR MOUNTED BATHTUB FILLER

KRUBBAS-K



WASTE COLUMN

COLSCAVK-K



INSPECTION PANEL FOR BUILT-IN BATHTUBS 60x33 CM

PANISPEL-A



BATHTUB EDGE PROFILE

PRV185-30

1 side cm 185

Measurements
(cm)

Bathtub	Code	Price
WITHOUT bath mounted cascade mixer		

Bathtub	Code	Price
WITH bath mounted cascade mixer		

STANDARD VERSION

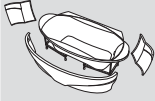
190 x 93 x 58 H		X3219092S-A3	
-----------------	---	---------------------	--

	X3219092S2-A3K	
--	-----------------------	--

FEATURES: Frame, 3 panels, removable seat, head rest, waste column

HYDRO VERSION

HYDRO VERSION

190 x 93 x 58 H		X3519092RS0-A3K	
-----------------	---	------------------------	--

	X3219092RS2-A3K	
--	------------------------	--

FEATURES: Frame, 3 panels, removable seat, head rest, waste column, whirlpool 6 jets, electronic panel

PLUS VERSION

190 x 93 x 58 H		X3719092RS6-A3K	
-----------------	---	------------------------	--

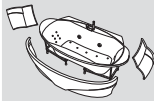
	X3719092RS7-A3K	
--	------------------------	--

FEATURES: Frame, 3 panels, removable seat, head rest, waste column, whirlpool 6 jets, airpool 12 jets, back airpool 6 nozzles, electronic panel, Chromo light, Disinfection system



Compulsory
Imperial to Metric flex
waste adaptor

Code	RISCCAB
Price	

For technical diagrams see page 208.

FLOOR-MOUNTED MIXER

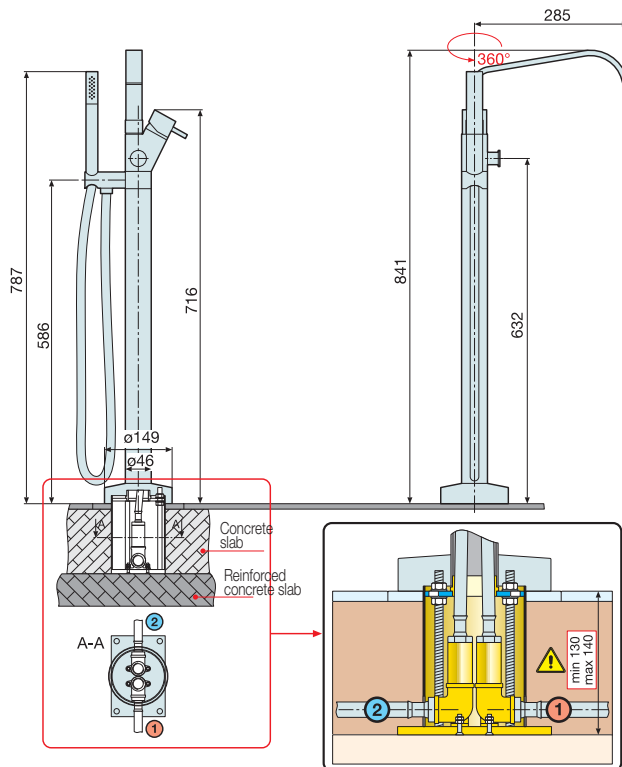

ATTENTION:

The column base must be installed before floor foundation. Please comply with the given measurements.

HYDRAULIC CHARACTERISTICS

- Optimum dynamic pressure 2-5 bar
- Bath filler water flow rate: 16 lit/min at 3 bar.
- Hand Shower water flow rate: 11 lit/min at 3 bar.

SENSE 1

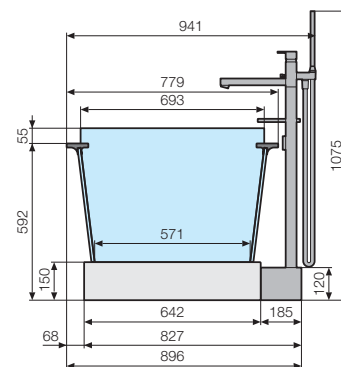
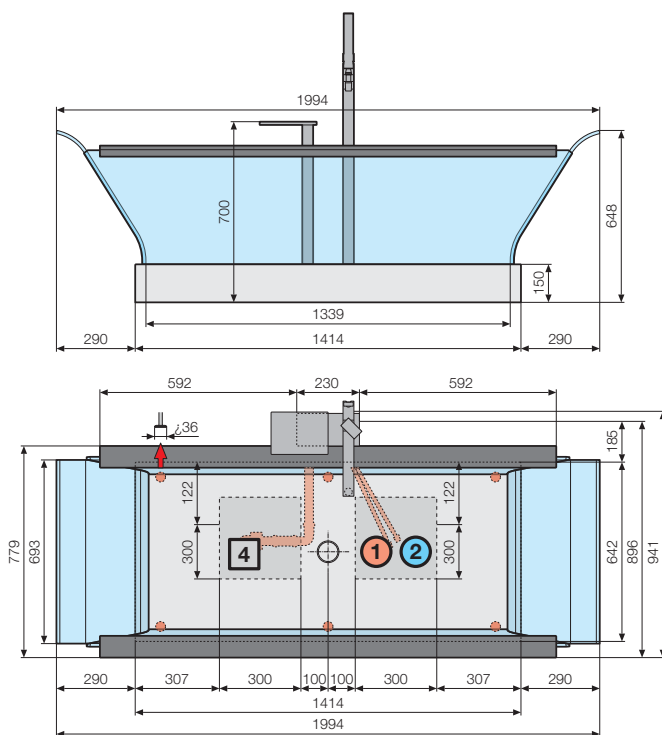

4 Recommended position for floor drainpipe.

HYDRAULIC CHARACTERISTICS

- Syphon connection 1 1/2"

Technical Diagrams

SENSE 5 - X1

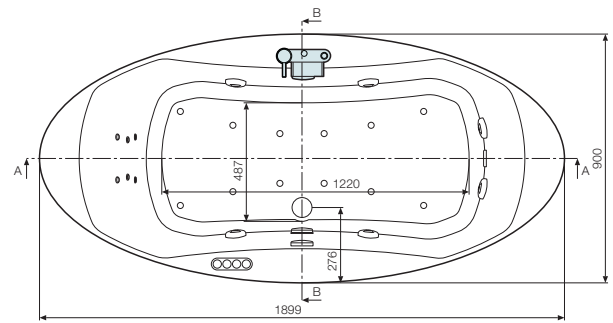
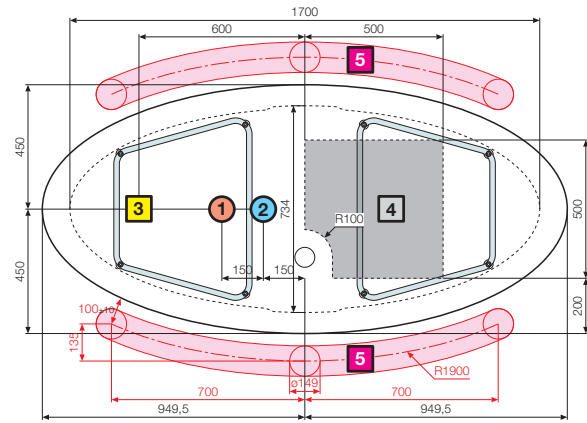
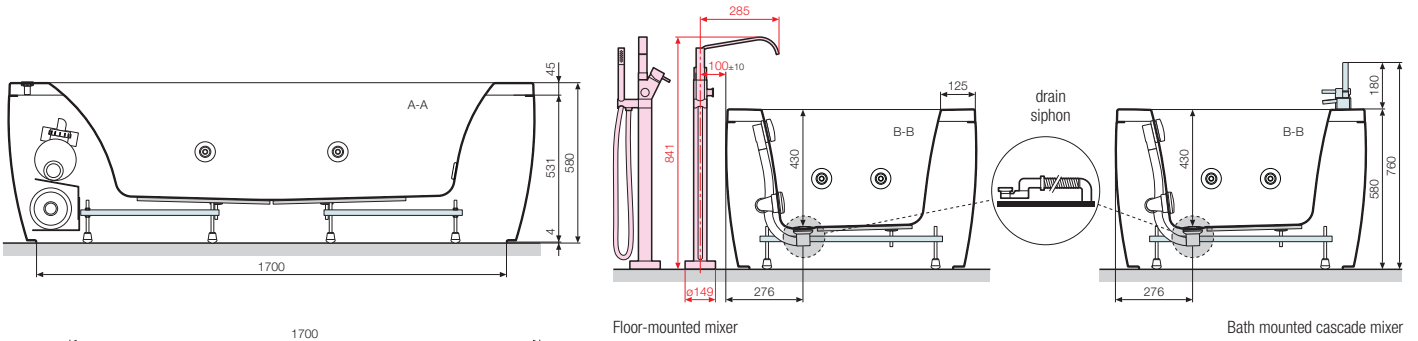

SENSE 5 - X3

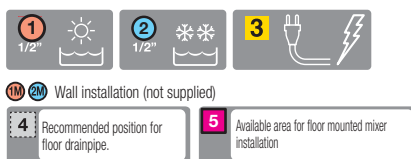
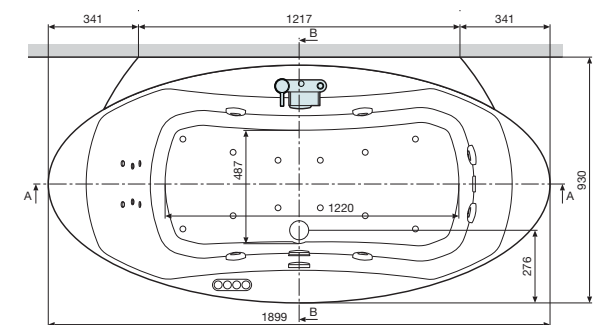
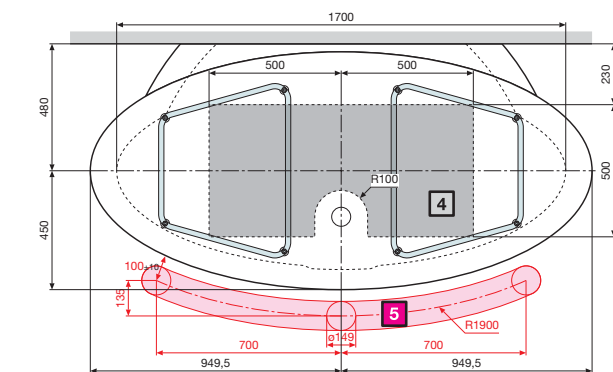
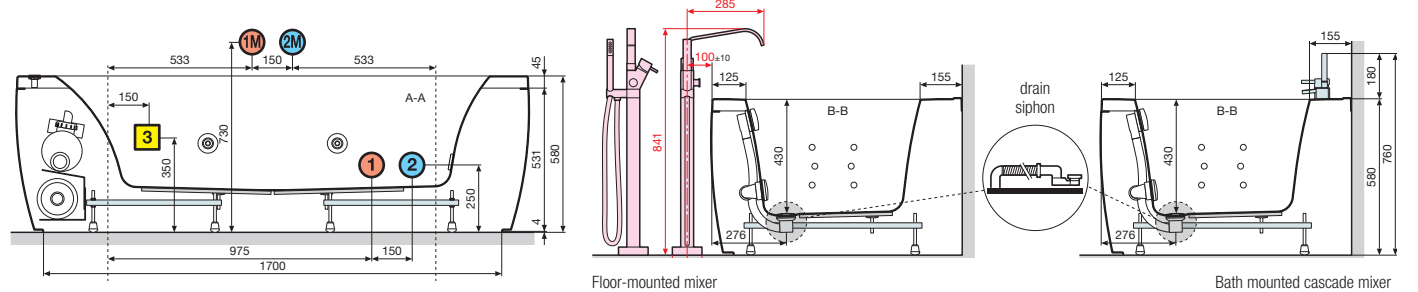

The whirlpool bath system must be fitted upstream with a 30 mA circuit breaker with a minimum contact of 3mm.

HYDRAULIC CHARACTERISTICS

- 6 whirlpool nozzles
- 12 airpool nozzles
- 6 back airpool nozzles
- Siphon connection with 1 1/2" coupling

ELECTRICAL CHARACTERISTICS

- Voltage 220-230 V
- Frequency 50 Hz
- Maximum absorbed power: whirlpool 880 W, airpool 900 W, whirlpool + airpool: 1800 W

Floor mounted mixer technical drawings pag. 202

Technical Diagrams

SENSE 5 - X2 right

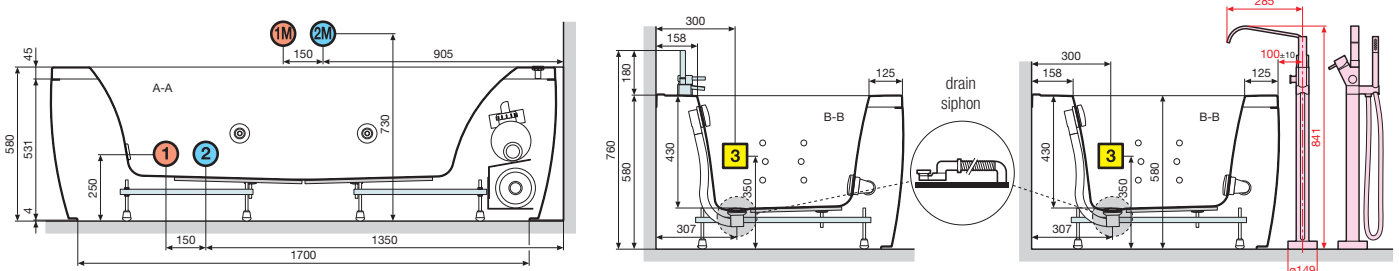

Bath mounted cascade mixer

Floor-mounted mixer

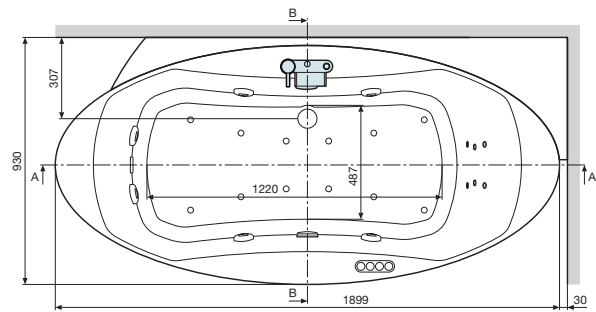
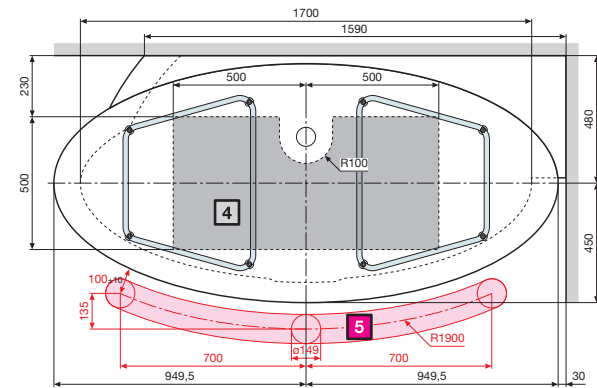

SENSE 5 - X2 left

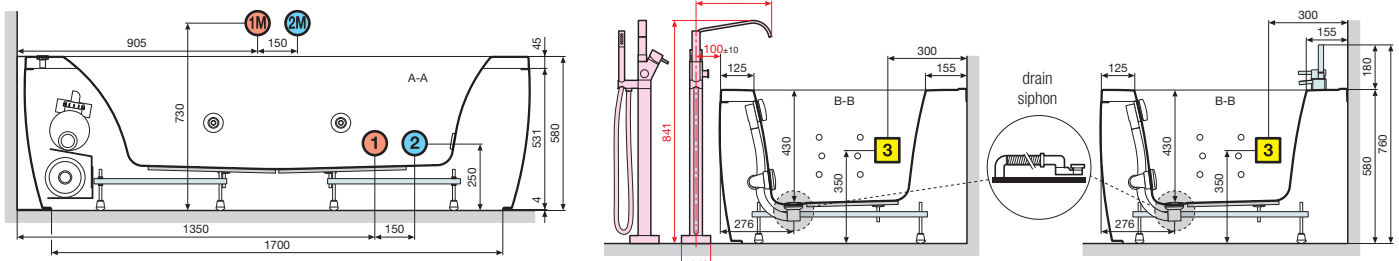

Floor-mounted mixer

Bath mounted cascade mixer

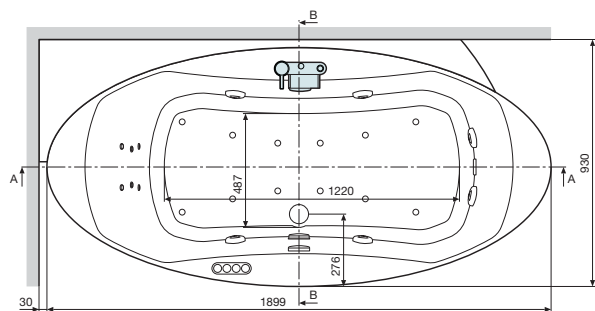
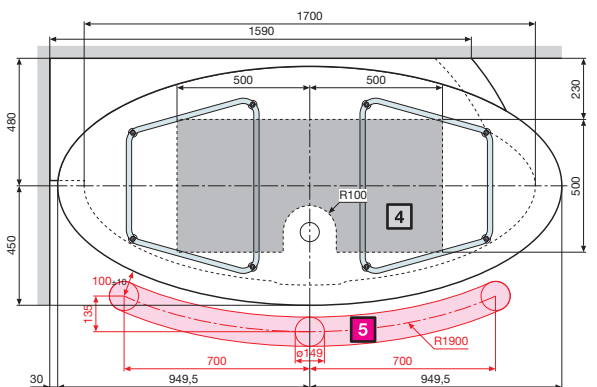

1 1/2"		2 1/2"		3	
1M 2M Wall installation (not supplied)					
4 Recommended position for floor drainpipe.			5 Available area for floor mounted mixer installation		

The whirlpool bath system must be fitted upstream with a 30 mA circuit breaker with a minimum contact of 3mm.

HYDRAULIC CHARACTERISTICS

- 6 whirlpool nozzles
- 12 airpool nozzles
- 6 back airpool nozzles
- Siphon connection with 1 1/2" coupling

ELECTRICAL CHARACTERISTICS

- Voltage 220-230 V
- Frequency 50 Hz
- Maximum absorbed power: whirlpool 880 W, airpool 900 W, whirlpool + airpool: 1800 W

Floor mounted mixer technical drawings pag. 202